

LoRa Module

WSL310S

Compact-sized
With Ultra-low Power
Consumption



LoRaWAN Support



WSL310S(L) : 470MHz
WSL310S(H) : 868MHz



AT Commands



Extended Temperature
Range: -40°C to +85°C



Ultra-Low Power Consumption
(1.5uA @ sleep mode)

The WSL310S transceivers SX126x feature the LoRa™ long range modem that provides ultra-long range spread spectrum communication and high interference immunity whilst minimising current consumption.

LoRa™ also provides significant advantages in both blocking and selectivity over conventional modulation techniques, solving the traditional design compromise between range, interference immunity and energy consumption.

◆ General Feature

- General LoRa module for Smart City, Smart Agriculture , Smart Industry, IOT Application
- Compact Form Factor: 16 x 18 x 2.5 mm
- 40 Pin Stamp Pad for PCB SMT mounting
- I/O port: UART/I2C/GPIO
- Temperature range: -40°C to +85°C
- Supply voltage: 2.0 ~ 3.6V
- Frequency range: 470 – 510 MHz(or 862 – 932 MHz),ISM and SRD systems
- IEEE 802.15.4g, Wireless M-Bus and Proprietary Systems
- Maximum 21dBm output power @ power boost mode
- Low-Power Wireless Systems with 7.8-kHz to 500-KHz Bandwidth

◆ Product Specifications

RF Function	
Standard	IEEE 802.15.4g
Interface	UART/I2C/GPIO
Transmit Output Power	21dBm
Data Rate	0.018 - 37.5 kbps
Modulation Techniques	Multilevel (G)FSK and MSK
Frequency bands	470 – 510 MHz or 862 – 932 MHz
Operating Voltage	2.0 ~ 3.6V
Operating Temperature	-40 ~ 85 degree C

◆ Power Consumption

SX1262 功耗測試			
中心頻率	設置發射功率	實測發射功率(dBm)	工作電流(mA)
Frequency	Program Power	Actual Power	Current
230MHZ	22	20	92
	20	19	83
	17	16	66
	14	12.9	54
470MHZ	22	20.5	95
	20	19.3	86
	17	16.1	71
	14	13.1	62
868MHZ	22	20.9	124
	20	20.2	118
	17	17.1	102
	14	14.2	90

Supply voltage=3.3V

Sleep mode

1.5

uA

◆ **MODULE PINOUT**

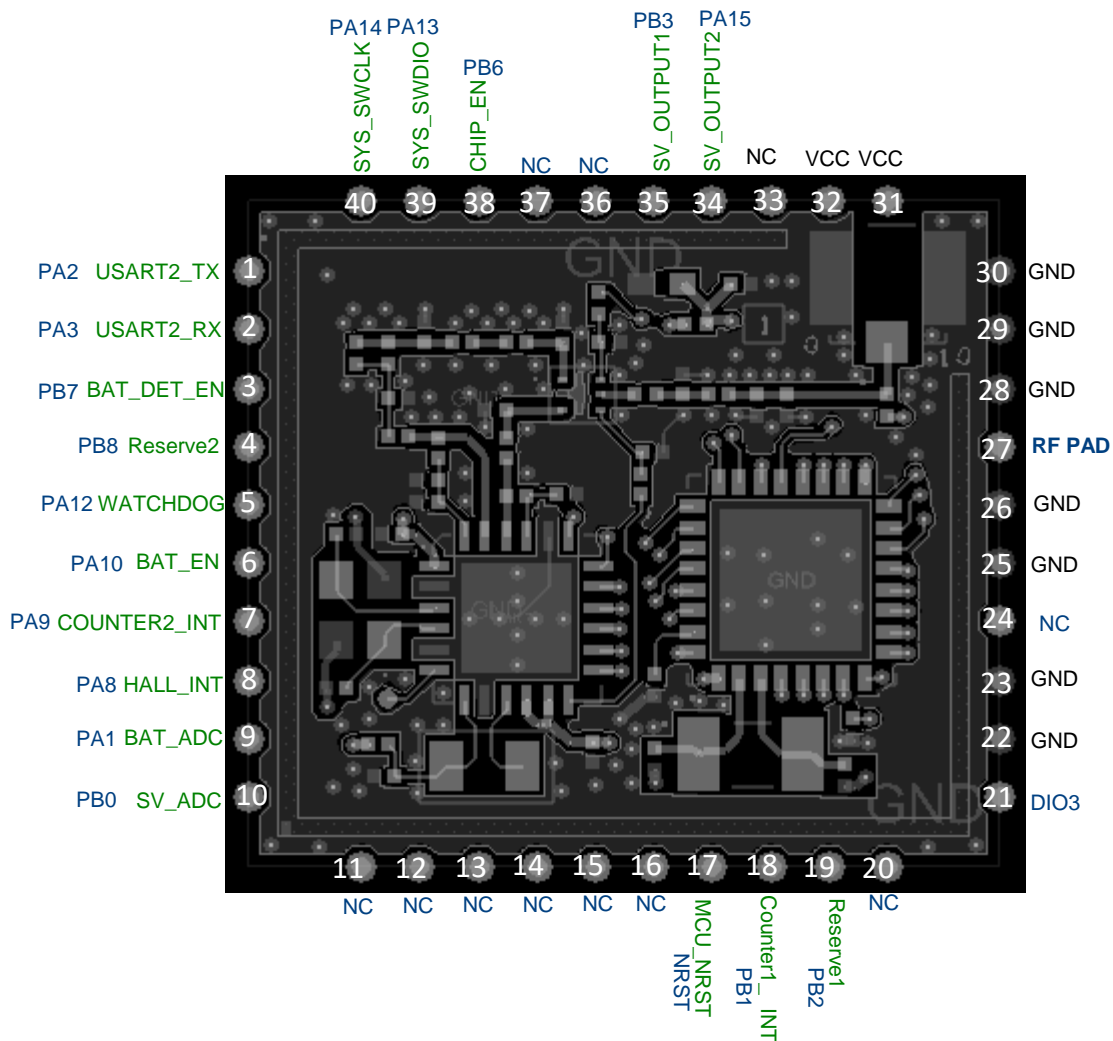

◆ **BLOCK DIAGRAM**

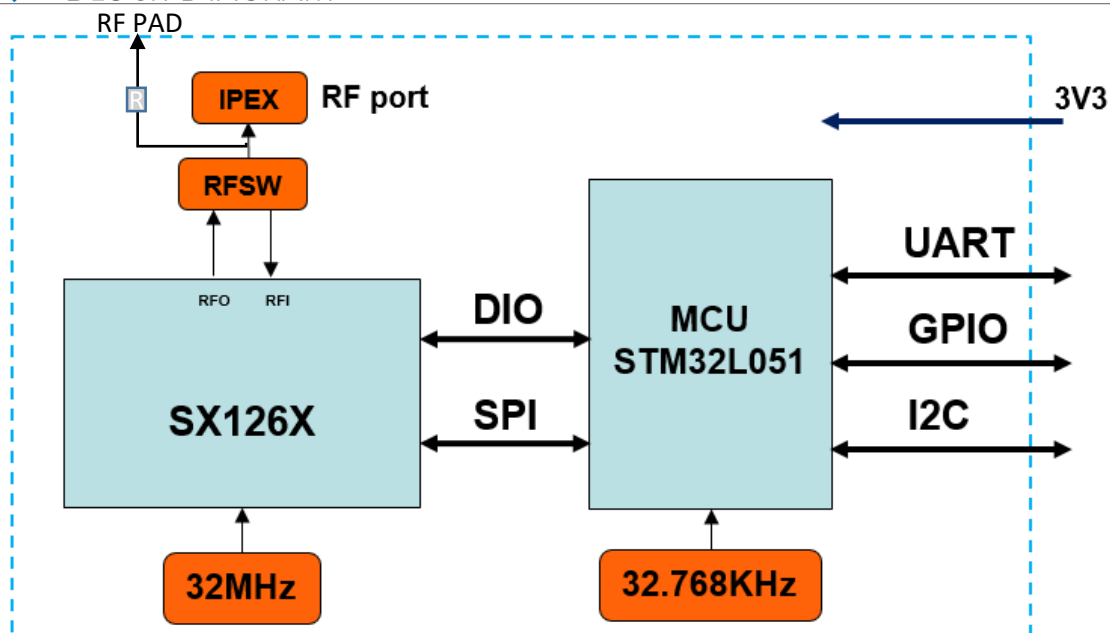

◆ **MODULE DIMENSION**

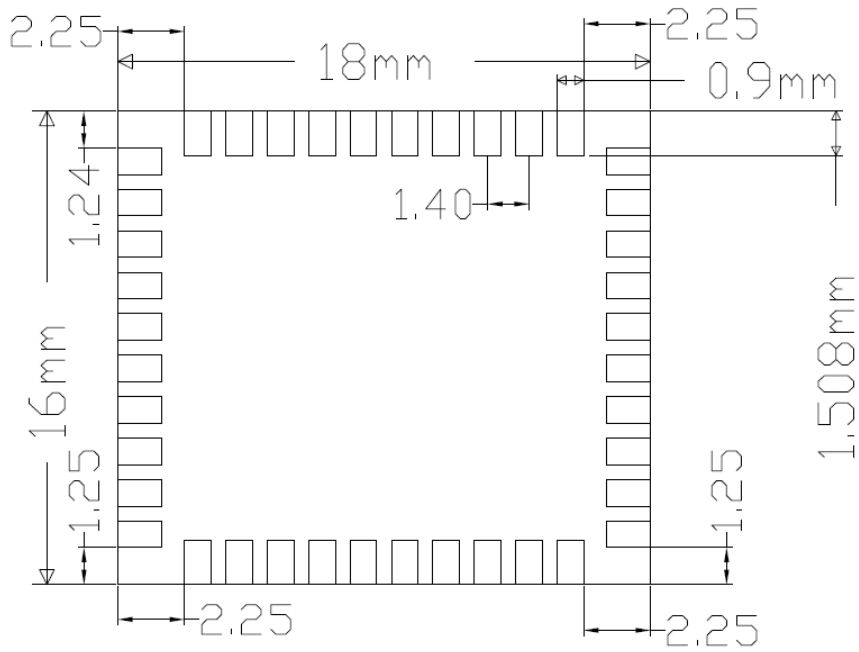

◆ **RECOMMENDED FOOTPRINT**

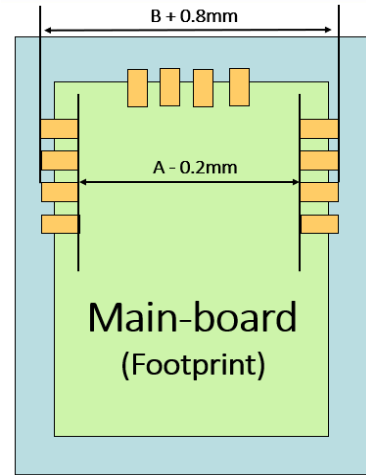
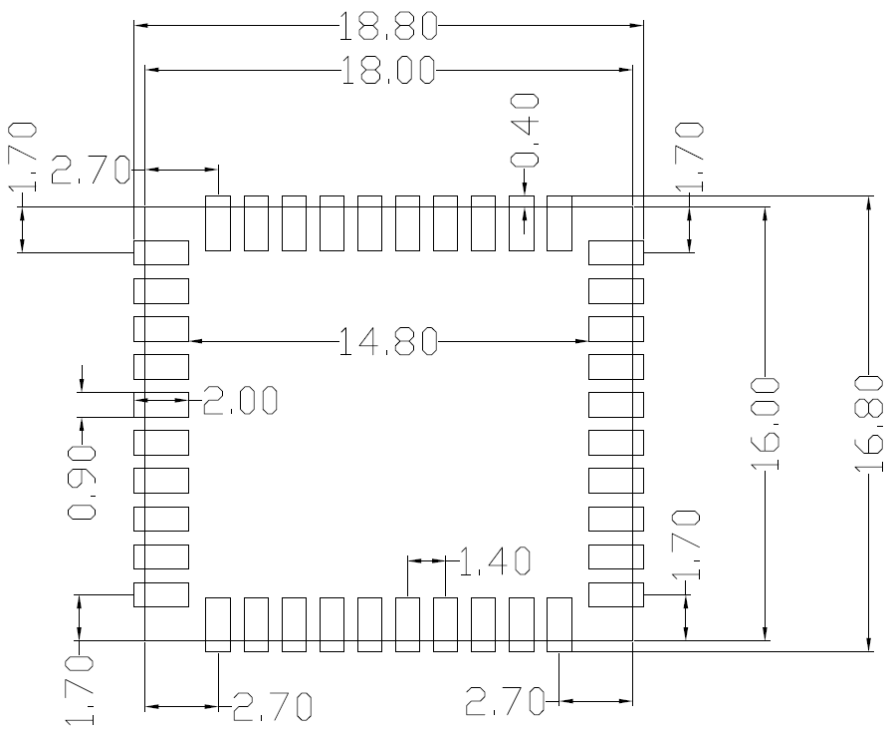

Pad

◆ RECOMMENDED STENCIL DESIGN

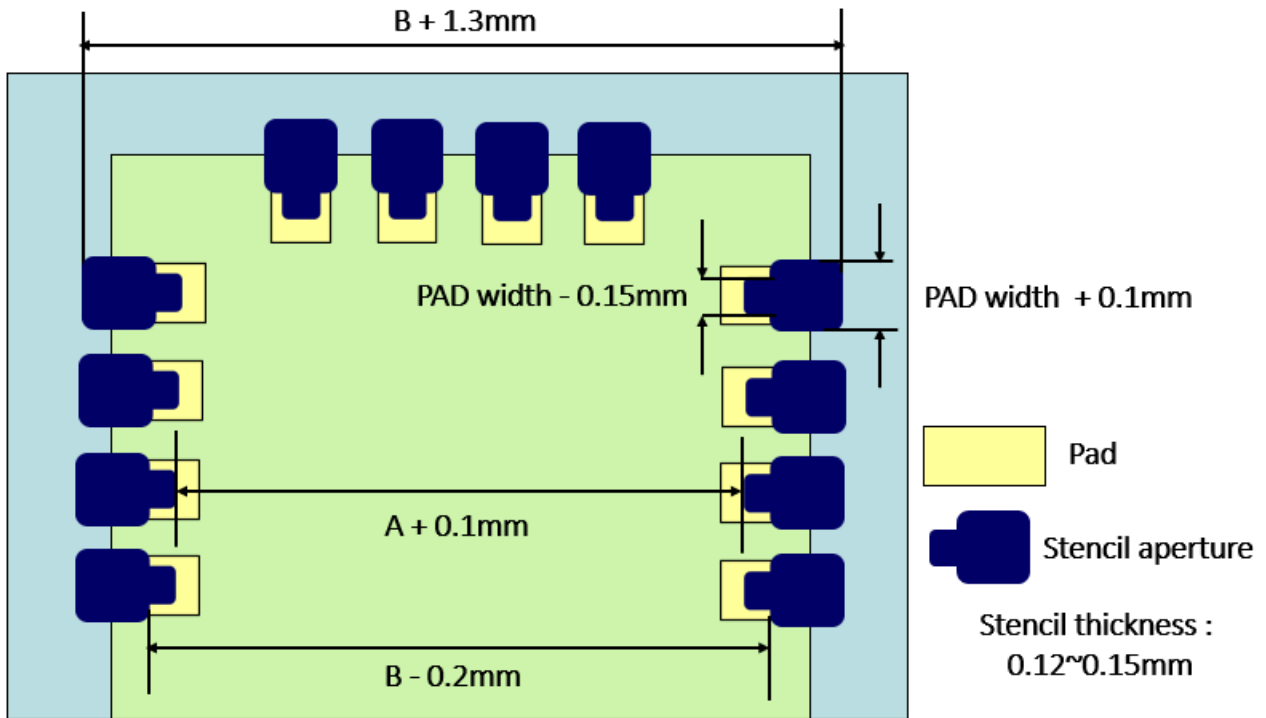

◆ **RECOMMENDED REFLOW PROFILE**

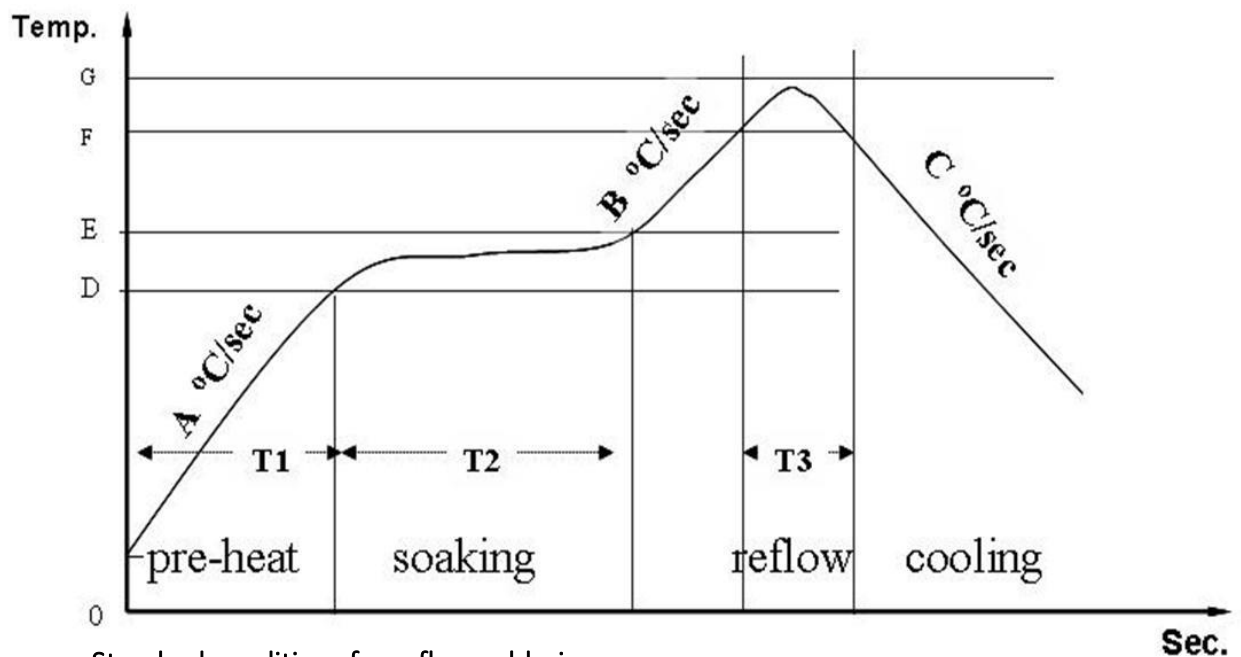

Standard conditions for reflow soldering:

- a. Pre-heating Ramp (A) (Initial temperature: 150°C): 1~2.5°C/sec;
- b. Soaking Time (T2) (150°C~180°C): 60sec~100sec;
- c. Peak Temperature (G): 230~250°C;
- d. Reflow Time (T3) (>220°C): 30~60 sec;
- e. Ramp-up Rate (B): 0~2.5°C/ sec;
- f. Ramp-down Rate (C): 1~3°C/ sec.

◆ **Additional Guidelines**

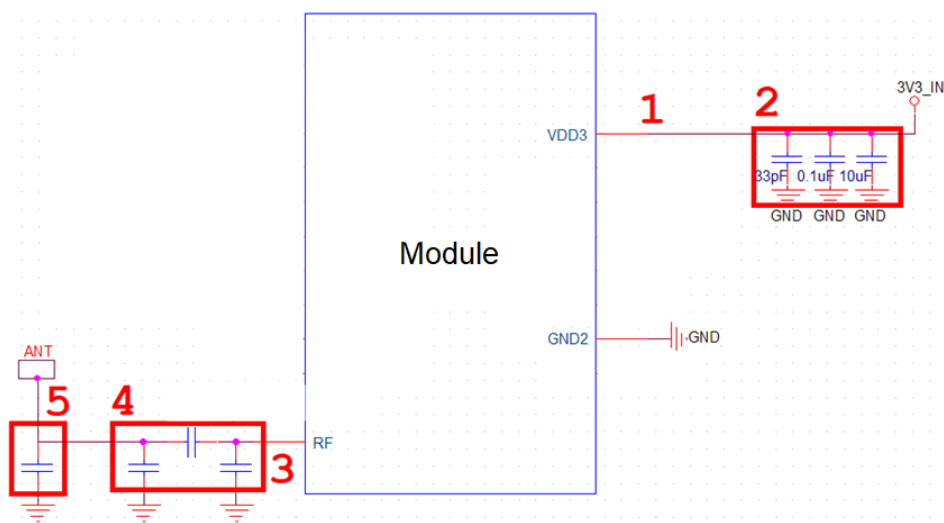

1. Power output routing width recommended more than 1mm.
2. Recommended to reserve capacitors to suppress ripple and noise.
3. RF output need routing with 50ohm impedance line.
4. Reserve the Pi-Matching for Antenna performance tuning.
5. Reserve the TVS for ESD protection. (Option)

LoRaWAN 無線模組之 AT 命令集列表

所有 AT 命令集的標準格式都是以 “@AT+XXX” 組成，其中 XXX 表示該命令。有四種可用的命令行為：

- @AT+XXX? 提供簡短的幫助於給定命令，例如 @AT+DEUI?
- @AT+XXX 用來執行命令，例如 @AT+JOIN
- @AT+XXX=? 會得到給定命令的價值，例如 @AT+CFS=?
- @AT+XXX=<value> 提供價值於命令，例如@AT+SEND=2:Hello

命令的輸出透過UART提供。輸出格式如下：

<value><CR><LF>

<CR><LF><Status<CR><LF>

Note: <CR> 代表 “carriage return” 而 <LF> 則為 “line feed”

無論何時執行“help AT+XXX?” 或 “get AT+XXX=?”，都會返回<value><CR><LF>輸出

當沒有返回值時，就不會返回<value> <CR> <LF>輸出。

每個命令（用於 MCU 復位的 ATZ 除外）都會返回一個狀態字符串，該字符串的前後是 <CR><LF> in a .”<CR><LF><Status<CR><LF>”。可能的狀況為：

Table 1.

Return	Status
OK	命令執行正確
AT_ERROR	一般錯誤
AT_PARAM_ERROR	該命令參數錯誤
AT_BUSY_ERROR: LoRa®	網絡忙碌，所以命令無法完成
AT_TEST_PARAM_OVERFLOW	該參數太長
AT_NO_NETWORK_JOINED: LoRa®	網絡忙碌尚未加入
AT_RX_ERROR	接收命令期間檢測錯誤

請參閱本節更多詳細信息關於每個命令的描述和範例。請注意以 # 開頭的每個命令都是主機向模塊提供的命令，然後刊印於模塊的返回。

1 一般命令

本節介紹命令相關之“意思”幫助列表，鏈接控制和 CPU AT_Slave 重置有關的命令。

1.1 @AT: attention

此命令用於檢查連線是否正常運作 (詳情參閱 [Table 2](#)).

Table 2. Link check command

Command	Input parameter	Return value	Return code
@AT	-	-	OK

1.2 @AT?: short help

該命令為所有支持的命令提供簡短的幫助 (詳情參閱 [Table 3](#)).

Table 3. Short help command

Command	Input parameter	Return value	Return code
@AT?	-	AT+<CMD>?: help on <CMD> AT+<CMD>: run <CMD> AT+<CMD>=<value>: set the value AT+<CMD>=? : get the value <followed by the help of all commands>	OK

1.3 @ATZ: MCU reset

該命令用於觸發模組MCU復位 (詳情參閱 [Table 4](#)).

Table 4. MCU reset command

Command	Input parameter	Return value	Return code
@ATZ?	-	ATZ: triggers a reset of the MCU	OK
@ATZ	-	No return value and return code. The MCU is reset.	Void

2 Keys, IDs and EUIs 管理

本節介紹與啟用終端設備相關的命令。

2.1 @AT+APPEUI: application identifier

該命令允許用戶存取 application identifier (詳情參閱 [Table 5](#)).

Table 5. Application identifier command

Command	Input parameter	Return value	Return code
@AT+APPEUI?	-	AT+APPEUI: get or set the application EUI	OK
@AT+APPEUI=?	-	<8 hex separated by:>	OK
@AT+APPEUI=<Param>	<8 hex separated by:>	-	OK / AT_PARAM_ERROR ⁽¹⁾
Example @AT+APPEUI=	01:02:03:04:05:06:07:08	-	OK
Example @AT+APPEUI=	01:02:03:04:05:06:07	-	AT_PARAM_ERROR ⁽¹⁾
Example @AT+APPEUI=?	-	01:02:03:04:05:06:07:08	OK

1. AT_PARAM_ERROR 表示設置錯誤或格式錯誤的值時會返回

2.2 @AT+APPKEY: application key

該命令允許用戶存取 application key (詳情參閱 [Table 6](#)).

Table 6. Application key command

Command	Input parameter	Return value	Return code
@AT+APPKEY?	-	AT+APPKEY: get or set the application key	OK
@AT+APPKEY=?	-	<16 hex separated by:>	OK
@AT+APPKEY=<Param>	<16 hex separated by:>	void	OK/ AT_PARAM_ERROR ⁽¹⁾
Example @AT+APPKEY=	01:2:a:FB:A1:CD:4D:20:0 1:02:30:40:5a:6b:7f:88	-	OK
Example @AT+APPKEY=	01:2:a:FB:A1:CD:4D:20:0 1:02:30:40:5a:6b:7f	-	AT_PARAM_ERROR ⁽¹⁾
Example @AT+APPKEY=?	-	2b:7e:15:16:28:ae:d2:a6: ab :f7:15:88:09:cf:4f:3c	OK

1. AT_PARAM_ERROR 表示設置錯誤或格式錯誤的值時會返回

2.3 @AT+APPSKEY: application session key

該命令允許用戶存取 application session key (詳情參閱 [Table 7](#)).

Table 7. Application session key command

Command	Input parameter	Return value	Return code
@AT+APPSKEY?	-	AT+APPSKEY: get or set the application session key	OK
@AT+APPSKEY=?	-	<16 hex separated by:>	OK
@AT+APPSKEY= <Param>	<16 hex separated by:>	void	OK / AT_PARAM_ERROR ⁽¹⁾
Example @AT+APPSKEY= 01:2:a:FB:A1:CD:4D:20:0 1:02:30:40:5a:6b:7f:88		-	OK
Example @AT+APPSKEY= 01:2:a:FB:A1:CD:4D:20:0 1:02:30:40:5a:6b:7f:		-	AT_PARAM_ERROR ⁽¹⁾
Example @AT+APPSKEY=?	-	df:bb:02:df:30:eb:7e:07:52:c 5:6d:8f:1d:e4:3f:37	OK

1. AT_PARAM_ERROR 表示設置錯誤或格式錯誤的值時會返回

2.4 @AT+DADDR: device address

該命令允許用戶存取 device address (詳情參閱 [Table 8](#)).

Table 8. Device address command

Command	Input parameter	Return value	Return code
@AT+DADDR?	-	AT+DADDR: get or set the device address	OK
@AT+DADDR=?	-	<4 hex separated by:>	OK
@AT+DADDR= <Param>	<4 hex separated by:>	-	OK / AT_PARAM_ERROR ⁽¹⁾
Example @AT+DADDR= 11:22:33:44		-	OK
Example @AT+DADDR=?	-	11:22:33:44	OK

1. AT_PARAM_ERROR 表示設置錯誤或格式錯誤的值時會返回

2.5 @AT+DEUI: device EUI

該命令允許用戶存取 device EUI (詳情參閱 [Table 9](#)).

Table 9. Device EUI command

Command	Input parameter	Return value	Return code
@AT+DEUI?	-	AT+DEUI: get or set the device EUI	OK
@AT+DEUI=?	-	<8 hex separated by:>	OK
@AT+DEUI= <Param>	<8 hex separated by:>	-	OK / AT_PARAM_ERROR ⁽¹⁾
Example @AT+DEUI?	-	11:22:33:44:55:66:77:88	OK
Example @AT+DEUI=	11:22:33:44:55:66:77:88	-	OK

1. AT_PARAM_ERROR 表示設置錯誤或格式錯誤的值時會返回

2.6 @AT+NWKSKEY: network session key

該命令允許用戶存取 network session key (詳情參閱 [Table 11](#)).

Table 11. Network session key command

Command	Input parameter	Return value	Return code
@AT+NWKSKEY?	-	AT+NWKSKEY: get or set the network session key	OK
@AT+NWKSKEY=?	-	<16 hex separated by:>	OK
@AT+NWKSKEY= <Param>	<16 hex separated by:>	-	OK / AT_PARAM_ERROR ⁽¹⁾
Example @AT+NWKSKEY=	0:1:2:3:4:5:6:7:8:9:A:B:C: D:E:F	-	OK
Example @AT+NWKSKEY=?	-	00:01:02:03:04:05:06:07:0 8:09:0A:0B:0C:0D:0E:0F	OK

1. AT_PARAM_ERROR 表示設置錯誤或格式錯誤的值時會返回

3 加入 LoRa® 網絡與發送數據

本節介紹與入網程序和數據路徑相關命令。

3.1 @AT+CFM: confirm mode

該命令允許用戶存取來自網絡收到的數據通知 (詳情參閱 [Table 12](#)).

Table 12. Confirm mode command

Command	Input parameter	Return value	Return code
@AT+CFM?	-	AT+CFM: get or set the confirm mode (0-1)	OK
@AT+CFM=?	-	0 or 1	OK
@AT+CFM= <Param>	0 or 1	-	OK / AT_PARAM_ERROR ⁽¹⁾
Example @AT+CFM=	1	-	OK
Example @AT+CFM=? ⁽²⁾	-	1	OK

1. AT_PARAM_ERROR 表示設置錯誤或格式錯誤的值時會返回

2. 當確認模式為 1 時，必須確認每條發送的消息。@AT+CFS=? 允許知道最近發送的消息是否已被確認。

3.2 @AT+CFS: confirm status

該命令允許用戶存取最後的“發送”命令的狀態 (詳情參閱 [Table 13](#))。

Table 13. Confirm status command

Command	Input parameter	Return value	Return code
@AT+CFS?	-	AT+CFS: get the confirmation status of the last AT+SEND (0-1)	OK
@AT+CFS=?	-	0 or 1	OK
Example @AT+CFS=?	-	0	OK

3.3 @AT+JOIN: join LoRa® network

該命令向網絡發出加入請求 (詳情參閱 [Table 14](#))。

Table 14. Join LoRa® network command

Command	Input parameter	Return value	Return code
@AT+JOIN?	-	AT+JOIN: join network	OK
@AT+JOIN	Void	Void	OK/ AT_BUSY_ERROR ⁽¹⁾ Join Fail ⁽²⁾
Example @AT+JOIN	-	-	OK

1. AT_BUSY_ERROR 表示已在加入過程中時返回
2. 入網時最少每個信道入網一次(8 信道各 1 次)，當 8 個信道都入網失敗時，則停止入網，並顯示”Join Fa
這是一個非同步命令，OK 表示連接正在執行，加入完成與否必須通過@AT + NJM = ? 來驗證。

3.4 @AT+NJM: LoRa® network join mode

該命令允許用戶存取網絡加入模式 (詳情參閱 [Table 15](#))。

Table 15. LoRa® network join mode command

Command	Input parameter	Return value	Return code
@AT+NJM?	-	AT+NJM: get or set the network join mode (0: ABP, 1: OTAA)	OK
@AT+NJM=?	-	0 or 1	OK
@AT+NJM=<Input>	0 or 1	-	OK/ AT_PARAM_ERROR ⁽¹⁾
Example @AT+NJM=?	-	0	OK
Example @AT+NJM=	1	-	OK
Example @AT+NJM=	2	-	AT_PARAM_ERROR ⁽¹⁾

1. AT_PARAM_ERROR 表示設置錯誤或格式錯誤的值時會返回

請留意即使是 ABP 入網也需要執行@AT + JOIN

3.5 @AT+NJS: LoRa® network join status

該命令允許用戶存取 LoRa® 連結的當前狀態 (詳情參閱 [Table 16](#)).

Table 16. LoRa® network join status command

Command	Input parameter	Return value	Return code
@AT+NJS?	-	AT+NJS: get the join status	OK
@AT+NJS=?	-	0 or 1	OK
Example @AT+NJS=?	-	0 (network not joined)	OK
Example @AT+NJS=?	-	1 (network joined)	OK

3.6 @AT+RECV: last received text data

該命令允許用戶以原始格式存取最近接收到的字串數據 (詳情參閱 [Table 17](#)).

Table 17. Last received text data command

Command	Input parameter	Return value	Return code
@AT+RECV?	-	AT+RECV: print the last received data in raw format	OK
@AT+RECV=?	-	<port>:raw (string format)	OK
Example @AT+RECV=?	-	45: hello world	OK

該命令以字串形式返回最後收到的數據以及接收數據的端口。輸出的格式為：

```
<port>:<text data><CR><LF>
```

```
<CR><LF>OK<CR><LF>
```

當兩次呼叫時，在呼叫之間沒有收到新的數據時，第二個@AT + RECV = ? 返回一個空白值，如下所示：

```
45:<CR><LF>
```

```
<CR><LF>OK<CR><LF>
```

3.7 @AT+RECVB: last received binary data

該命令允許用戶以二進制格式存取上次接收到的字串數據 (詳情參閱 [Table 18](#))。如表中所示，二進制數據在端口 45 上被接收。

Table 18. Last received binary data command

Command	Input parameter	Return value	Return code
@AT+RECVB?	-	AT+RECVB: print the last received data in in binary format (with hexadecimal values)	OK
@AT+RECVB=?	-	<port>:<binary>	OK
Example @AT+RECVB=?	-	45:48656c6c6f20576f726c64	OK

3.8 @AT+SEND: send text data

該命令提供了在專用端口號上發送字串數據的方式 (詳情參閱 [Table 19](#))。如表中所示，字串數據在端口 12 上被接收。

Table 19. Send text data command

Command	Input parameter	Return value	Return code
@AT+SEND?	-	AT+SEND: send text data along with the application port	OK
@AT+SEND=<input>	port text	-	OK/ AT_PARAM_ERROR ⁽¹⁾ / Send OK ⁽²⁾
Example @AT+SEND=	12: hello world	-	OK

1. AT_PARAM_ERROR 當<port>:<text>設置的格式不正確時被返回, <port>為一個十進制值
2. 當傳送完畢後會 return "Send OK"

3.9 @AT+SENDB: send binary data

該命令提供了在專用端口數字上以二進制格式發送字串數據的方式 (詳情參閱 [Table 20](#))。二進制數據的每個字節都以兩個字符的形式表示，以十六進製表示。因此二進制數據的長度總是偶數。如表中所示，在端口 12 上發送 8 個字節：0xab，0xcd，0xef，0x0 (請留意訊息“01”僅表示“1”將失敗)，0x23，0x45，0x67 和 0x89。

Table 20. Send binary data command

Command	Input parameter	Return value	Return code
@AT+SENDB?	-	AT+SENDB: send hexadecimal data along with the application port	OK
@AT+SENDB=<input>	<port>:<binary>	-	OK/ AT_PARAM_ERROR ⁽¹⁾ / Send OK ⁽²⁾
Example @AT+SENDB=	12:abcdef0123456789	-	OK
Example @AT+SENDB=	abcdef0123456789	-	AT_PARAM_ERROR ⁽¹⁾

1. AT_PARAM_ERROR 當<port>:<binary>設置的格式不正確時返回, <port>為一個十進制值,<binary>後面的十六進制格式使用上述 2 個字符返回。
2. 當傳送完畢後會 return "Send OK"

4 LoRa® 網絡管理

本節提供一組網絡管理命令。

4.1 @AT+ADR: adaptive rate

該命令允許用戶存取自適應數據速率 (詳情參閱 [Table 21](#))，ADR 的設定值為 1 (啟用)。

Table 21. Adaptive rate command

Command	Input parameter	Return value	Return code
@AT+ADR?	-	AT+ADR: get or set the adaptive data rate setting (0: off, 1: on)	OK
@AT+ADR=?	-	0 or 1	OK
@AT+ADR=<Input>	0 or 1	-	OK
Example @AT+ADR=	0	-	OK/ AT_PARAM_ERROR ⁽¹⁾ / AT_BUSY_ERROR ⁽²⁾
Example @AT+ADR=?	-	0	OK

1. AT_PARAM_ERROR 表示設置錯誤或格式錯誤的值時會返回
2. AT_BUSY_ERROR 當加入或發送正在處理中返回

4.2 @AT+CLASS: LoRa® class

該命令允許用戶存取 LoRaWAN™ 類別 (詳情參閱 [Table 22](#)).

Table 22. LoRa® class command

Command	Input parameter	Return value	Return code
@AT+CLASS?	-	AT+CLASS: get or set the device class	OK
@AT+CLASS=?	-	A, B, or C	OK
@AT+CLASS=<Input>	A, B or C		OK/ AT_PARAM_ERROR ⁽²⁾ AT_BUSY_ERROR ⁽³⁾
Example @AT+CLASS=?	-	A	OK

1. 此版本僅支持 A 類
2. AT_PARAM_ERROR 表示設置錯誤或格式錯誤的值時會返回
3. AT_BUSY_ERROR 當加入或發送正在處理中返回

4.3 @AT+DCS: duty cycle settings

該命令允許用戶存取佔空比參數 (詳情參閱 [Table 23](#)).

Table 23. Duty cycle settings command

Command	Input parameter	Return value	Return code
@AT+DCS?	-	AT+DCS: get or set the ETSI duty cycle setting: 0=disable, 1=enable - only for testing	OK
@AT+DCS=?	-	0 or 1	OK
@AT+DCS=<Input>	0 or 1	-	OK/ AT_PARAM_ERROR ⁽¹⁾ AT_BUSY_ERROR ⁽²⁾
Example @AT+DCS=?	-	1	OK
Example @AT+DCS=	1	-	OK

1. AT_PARAM_ERROR 表示設置錯誤或格式錯誤的值時會返回
2. AT_BUSY_ERROR 當加入或發送正在處理中返回

4.4 @AT+DR: data rate

該命令允許用戶存取數據速率 (詳情參閱 [Table 24](#)).

Table 24. Data rate command

Command	Input parameter	Return value	Return code
@AT+DR?	-	AT+DR: get or set the data rate (0-7 corresponding to DR_X)<	OK
@AT+DR=?	-	[0,1,2,3,4,5,6,7]	OK
@AT+DR=<Input>	[0,1,2,3,4,5,6,7]	-	OK/ AT_PARAM_ERROR ⁽¹⁾ AT_BUSY_ERROR ⁽²⁾
Example @AT+DR=?	-	3	OK
Example @AT+DR=	2	-	OK

1. AT_PARAM_ERROR 表示設置錯誤或格式錯誤的值時會返回
2. AT_BUSY_ERROR 當加入或發送正在處理中返回

4.5 @AT+FCD: frame counter downlink

該命令允許用戶存取下行幀計數器 (詳情參閱 [Table 25](#)).

Table 25. Data rate command

Command	Input parameter	Return value	Return code
@AT+FCD?	-	AT+FCD: get or set the downlink frame counter	OK
@AT+FCD=?	-	<integer>	OK
@AT+FCD=<Input>	<integer>	-	OK/ AT_PARAM_ERROR ⁽¹⁾ AT_BUSY_ERROR ⁽²⁾
Example @AT+FCD=?	-	4294967295	OK
Example @AT+FCD=<Input>	10	-	OK

1. AT_PARAM_ERROR 表示設置錯誤或格式錯誤的值時會返回
2. AT_BUSY_ERROR 當加入或發送正在處理中返回

4.6 @AT+FCU: frame counter uplink

該命令允許用戶存取上行幀計數器 (詳情參閱 [Table 26](#)).

Table 26. Frame counter uplink command

Command	Input parameter	Return value	Return code
@AT+FCU?	-	AT+FCU: get or set the uplink frame counter	OK
@AT+FCU=?	-	<integer>	OK
@AT+FCU=<Input>	<integer>	-	OK/ AT_PARAM_ERROR ⁽¹⁾ AT_BUSY_ERROR ⁽²⁾
Example @AT+FCU=?	-	4294967295	OK
Example @AT+FCU=<Input>	10	-	OK

1. AT_PARAM_ERROR 表示設置錯誤或格式錯誤的值時會返回
2. AT_BUSY_ERROR 當加入或發送正在處理中返回

4.7 @AT+JN1DL: join delay on RX window 1

該命令允許用戶存取 RX 窗口 1 上的延遲加入 (詳情參閱 [Table 27](#))

Table 27. Join delay on RX window 1 command

Command	Input parameter	Return value	Return code
@AT+JN1DL?	-	AT+JN1DL: get or set the joint accept delay between the end of the Tx and the join Rx window 1 in ms	OK
@AT+JN1DL=?	-	<integer>	OK/ AT_BUSY_ERROR ⁽¹⁾
@AT+JN1DL=<input>	<integer>	-	OK/ AT_PARAM_ERROR ⁽²⁾ AT_BUSY_ERROR ⁽¹⁾
Example @AT+JN1DL=?	-	5000	OK
Example @AT+JN1DL=	10000	-	OK

1. AT_BUSY_ERROR 當加入或發送正在處理中返回
2. AT_PARAM_ERROR 表示設置錯誤或格式錯誤的值時會返回

4.8 @AT+JN2DL: join delay on RX window 2

此命令允許用戶存取 RX 窗口 2 上的延遲加入 (詳情參閱 [Table 28](#)) .

Table 28. Join delay on RX window 2 command

Command	Input parameter	Return value	Return code
@AT+JN2DL?	-	AT+JN2DL: get or set the joint accept delay between the end of the Tx and the join Rx window 2 in ms	OK
@AT+JN2DL=?	-	<integer>	OK/ AT_BUSY_ERROR ⁽¹⁾
@AT+JN2DL=<input>	<integer>	-	OK/ AT_PARAM_ERROR ⁽²⁾ AT_BUSY_ERROR ⁽¹⁾
Example @AT+JN2DL=?	-	6000	OK
Example @AT+JN2DL=	20000	-	OK

1. AT_BUSY_ERROR 當加入或發送正在處理中返回
2. AT_PARAM_ERROR 表示設置錯誤或格式錯誤的值時會返回

4.9 @AT+PNM: public network mode

該命令允許用戶存取公共網絡模式 (詳情參閱 [Table 29](#))

Table 29. Public network mode command

Command	Input parameter	Return value	Return code
@AT+PNM?	-	AT+PNM: get or set the public network mode (0:off, 1:on).	OK
@AT+PNM=?	-	0 or 1	OK
@AT+PNM=<input>	0 or 1	-	OK/ AT_PARAM_ERROR ⁽¹⁾
Example @AT+PNM=?	-	0	OK
Example @AT+PNM=	1	-	OK
Example @AT+PNM=	2	-	AT_PARAM_ERROR ⁽¹⁾

1. AT_PARAM_ERROR 表示設置錯誤或格式錯誤的值時會返回

4.10 @AT+RX1DL: delay of the received window 1

此命令允許用戶存取接收到的窗口 1 的延遲 (詳情參閱 [Table 30](#)).

Table 30. Delay of the received window 1 command

Command	Input parameter	Return value	Return code
@AT+RX1DL?	-	AT+RX1DL: get or set the delay between the end of the Tx and the Rx window 1 in ms	OK
@AT+RX1DL=?	-	<integer>	OK/ AT_BUSY_ERROR ⁽¹⁾
@AT+RX1DL=<input>	<integer>	-	OK/ AT_PARAM_ERROR ⁽²⁾ AT_BUSY_ERROR ⁽¹⁾
Example @AT+RX1DL=?	-	1000	OK
Example @AT+RX1DL=	1500	-	OK

1. AT_BUSY_ERROR 當加入或發送正在處理中返回
2. AT_PARAM_ERROR 表示設置錯誤或格式錯誤的值時會返回

4.11 @AT+RX2DL: delay of the received window 2

該命令允許用戶存取接收到的窗口 2 的延遲 (詳情參閱 [Table 31](#)).

Table 31. Delay of the received window 2 command

Command	Input parameter	Return value	Return code
@AT+RX2DL?	-	AT+RX2DL: get or set the delay between the end of the Tx and the Rx window 2 in ms	OK
@AT+RX2DL=?	-	<integer>	OK/ AT_BUSY_ERROR ⁽¹⁾
@AT+RX2DL=<input>	<integer>	-	OK/ AT_PARAM_ERROR ⁽²⁾ AT_BUSY_ERROR ⁽¹⁾
Example @AT+RX2DL=?	-	2000	OK
Example @AT+RX2DL=	2500	-	OK

1. AT_BUSY_ERROR 當加入或發送正在處理中返回
2. AT_PARAM_ERROR 表示設置錯誤或格式錯誤的值時會返回

4.12 @AT+RX2DR: data rate of the received window 2

該命令允許用戶存取接收到的窗口 2 的數據速率 (詳情參閱 [Table 32](#))。

Table 32. Data rate of the received window 2 command

Command	Input parameter	Return value	Return code
@AT+RX2DR?	-	AT+RX2DR: get or set the Rx2 window data rate (0-5) corresponding to DR_X	OK
@AT+RX2DR=?	-	[0,1,2,3,4,5]	OK/ AT_BUSY_ERROR ⁽¹⁾
@AT+RX2DR=<input>	[0,1,2,3,4,5]	-	OK/ AT_PARAM_ERROR ⁽²⁾ AT_BUSY_ERROR ⁽¹⁾
Example @AT+RX2DR=?	-	5	OK
Example @AT+RX2DR=	5	-	OK

1. AT_BUSY_ERROR 當加入或發送正在處理中返回
2. AT_PARAM_ERROR 表示設置錯誤或格式錯誤的值時會返回

4.13 @AT+RX2FQ: frequency of the received window 2

該命令允許用戶存取接收到的窗口 2 的頻率 (詳情參閱 [Table 33](#))。

Table 33. Frequency of the received window 2 command

Command	Input parameter	Return value	Return code
@AT+RX2FQ?	-	AT+RX2FQ: get or set the Rx2 window frequency	OK
@AT+RX2FQ=?	-	Frequency in Hz	OK/ AT_BUSY_ERROR ⁽¹⁾
@AT+RX2FQ=8695350000	Frequency in Hz	-	OK/ AT_PARAM_ERROR ⁽²⁾ AT_BUSY_ERROR ⁽¹⁾
Example @AT+RX2FQ=?	-	869535000	OK
Example @AT+RX2FQ=	869535000	-	OK

1. AT_BUSY_ERROR 當加入或發送正在處理中返回
2. AT_PARAM_ERROR 表示設置錯誤或格式錯誤的值時會返回

4.14 @AT+TXP: transmit power

該命令允許用戶存取發射功率 (詳情參閱 [Table 34](#)).

Table 34. Transmit power command

Command	Input parameter	Return value	Return code
@AT+TXP?	-	AT+TXP: get or set the transmit power (0-7)	OK
@AT+TXP=?	-	[0,1,2,3,4,5,6,7] ⁽²⁾	OK AT_PARAM_ERROR ⁽¹⁾
@AT+TXP=<input>	[0,1,2,3,4,5,6,7] ⁽²⁾	-	OK AT_PARAM_ERROR ⁽¹⁾
Example @AT+TXP=?	-	1	OK
Example @AT+TXP=	4	-	OK

1. AT_PARAM_ERROR 表示設置錯誤或格式錯誤的值時會返回
2. 0~7 代表 0: 17dBm, 1: 15dBm, 2: 13dBm, 3: 11dBm, 4: 9dBm, 5: 7dBm, 6: 5dBm, 7: 3dBm

5 資訊

本節提供了一組電池級別，RF 信號質量和 FW 版本的命令。

5.1 @AT+RSSI: RSSI on reception

該命令允許用戶在接收時存取 RSSI (詳情參閱 [Table 36](#)).

Table 36. RSSI on reception command

Command(1)	Input parameter	Return value	Return code
@AT+RSSI?	-	AT+RSSI: get the RSSI of the last received packet	OK
@AT+RSSI=?	-	integer	OK
Example @AT+RSSI=?	-	-31	OK

1. @At+RSSI=? 提供以 dBm 為單位的值

5.2 @AT+SNR: signal noise ratio

該命令允許用戶存取最後收到的 SNR 數據組 (詳情參閱 [Table 37](#)).

Table 37. Signal noise ratio command

Command(1)	Input parameter	Return value	Return code
@AT+SNR?	-	AT+SNR: get the SNR of the last received packet	OK
@AT+SNR=?	-	integer	OK
Example @AT+SNR=?	-	32	OK

1. @At+SNR=? 提供以 dBm 為單位的值

5.3 @AT+VER: version of the firmware

該命令允許用戶存取模組韌體版本 (詳情參閱 [Table 38](#)).

Table 38. Version of the firmware command

Command	Input parameter	Return value	Return code
@AT+VER?	-	AT+VER: get the version of the AT_iSlave FW	OK
@AT+VER=?	-	F-ICM-XX-XXXXXXX	OK
Example @AT+VER=?	-	F-ICM-XX-XXXXXXX	OK

6 RF 測試

本節為 RF 測試管理提供了一組命令。

6.1 @AT+TRSSI: Start Radio Frequency RSSI Tone test

該命令允許用戶啟動 RF RSSI 頻率測試 (詳情參閱 [Table 39](#)).

Table 39. Start Radio Frequency RSSI Tone command

Command	Input parameter	Return value	Return code
@AT+TRSSI?	-	AT+TRSSI: start RF RSSI tone test	OK
@AT+TRSSI	Void	Void	OK AT_BUSY_ERROR ⁽¹⁾
Example @AT+TRSSI	-	-	OK

1. AT_BUSY_ERROR 當加入或發送正在處理中返回

6.2 @AT+TTONE: Start Radio Frequency Tone test

此命令允許用戶啟動 RF 頻率測試 (詳情參閱 [Table 40](#)).

Table 40. Start Radio Frequency Tone test command

Command	Input parameter	Return value	Return code
@AT+TTONE?	-	AT+TTONE: start RF tone test	OK
@AT+TTONE	Void	Void	OK AT_BUSY_ERROR ⁽¹⁾
Example @AT+TTONE	-	-	OK

1. AT_BUSY_ERROR 當加入或發送正在處理中返回

6.3 @AT+TTLRA: Start RF Tx LoRa® test

該命令允許用戶啟動 RF Tx LoRa® 測試 (詳情參閱 [Table 41](#)).

Table 41. Start RF Tx LoRa® test command

Command	Input parameter	Return value	Return code
@AT+TTLRA?	-	AT+TTLRA: starts Tx LoRa® test	OK
@AT+TTLRA	Void	Void	OK AT_BUSY_ERROR ⁽¹⁾
Example @AT+TTLRA	-	-	OK

1. AT_BUSY_ERROR 當加入或發送正在處理中返回

6.4 @AT+TRLRA: Start RF Rx LORA test

該命令允許用戶啟動 RF Rx LoRa® 測試 (詳情參閱 [Table 42](#)).

Table 42. Start RF Rx LoRa® test command

Command	Input parameter	Return value	Return code
@AT+TRLRA?	-	AT+TRLRA: starts Rx LoRa® test	OK
@AT+TRLRA	Void	Void	OK AT_BUSY_ERROR ⁽¹⁾
Example @AT+TRLRA	-	-	OK

1. AT_BUSY_ERROR 當加入或發送正在處理中返回

6.5 @AT+TCONF: Config LoRa® RF test

該命令允許用戶存取 LoRa®測試設定 (詳情參閱 [Table 43](#)).

Table 43. Config LoRa® RF test command

Command	Input parameter	Return value	Return code
@AT+TCONF?	-	AT+TCONF: configure LoRa® RF test	OK
@AT+TCONF=?	Void	Void	OK AT_ERROR
@AT+TCONF= <param>	Void	Void	OK AT_PARAM_ERROR ⁽¹⁾
Example @AT+TCONF=?	-	Freq = 868 MHz Power = 14 dbm Bandwidth = 125 KHz SF = 12 CR = 4 / 8 LNA State = 0 PA boost state = 1	OK
Example @AT+TCONF= 868:12:125:12: 4/8:0:1	868:12:125:12: 4/8:0:1	-	OK
Example @AT+TCONF= 868:12:300:12: 4/8:0:1	868:12:300:12: 4/8:0:1	-	AT_PARAM_ERROR ⁽¹⁾ (error on bandwidth setting)

1. AT_PARAM_ERROR 表示設置錯誤或格式錯誤的值時會返回

AT_PARAM_ERROR 當設置沒有正確的格式(十進制值)或超出要求的設置時，將返回:

- Bandwidth = {125, 250, 500};
- SF = {7, 8, 9, 10, 11, 12};
- CR = {4/5, 4/6, 4/7, 4/8}.

6.6 @AT+TOFF: Stop ongoing Radio Frequency test

該命令允許用戶停止正在進行的 RF 測試 (詳情參閱 [Table 44](#)).

Table 44. Stop Radio Frequency test command

Command	Input parameter	Return value	Return code
@AT+TOFF?	-	AT+TOFF: stop ongoing RF test	OK
@AT+TOFF	Void	Void	OK

6.7 @AT+CERTIF: Set the module in LoRaWAN™ Certification Mode

該命令允許用戶啟動 RF Rx LoRa 測試 (詳情參閱 [Table 45](#)).

Table 45. Set the module in LoRaWAN™ Certification Mode command

Command	Input parameter	Return value	Return code
@AT+CERTIF?	-	AT+CERTIF: set the module in LoraWAN™ Certification Mode	OK
@AT+CERTIF	Void	Void	OK AT_BUSY_ERROR ⁽¹⁾

1. AT_BUSY_ERROR 當加入或發送正在處理中返回
@AT+CERTIF 將處理數據傳輸定時為 5 秒。

7 客需命令

本節介紹客需之命令

7.1 @AT+TRX: Set the frequency of Rx1 is equal to the frequency of Tx

該命令允許用戶存取 Rx1 頻率等於 Tx 頻率 (詳情參閱 [Table 46](#)).

Table 46. LoRa® network join mode command

Command	Input parameter	Return value	Return code
@AT+TRX?	-	AT+TRX: 設定是否接收 頻率跟隨發射頻率(0:關 閉 1:開啟)	OK
@AT+TRX=?	-	0 or 1	OK
@AT+TRX=<Input>	0 or 1	-	OK/ AT_PARAM_ERROR ⁽¹⁾
Example @AT+TRX=?	-	0	OK
Example @AT+TRX=	1	-	OK
Example @AT+TRX=	2	-	AT_PARAM_ERROR ⁽¹⁾

1. AT_PARAM_ERROR 表示設置錯誤或格式錯誤的值時會返回

7.2 @AT+RX1FQ: frequency of the received window 1

該命令允許用戶存取接收到的窗口 1 的頻率 (詳情參閱 [Table 47](#)).

Table 47. Frequency of the received window 2 command

Command	Input parameter	Return value	Return code
@AT+RX1FQ?	-	AT+RX1FQ: get or set the Rx1 window frequency	OK
@AT+RX1FQ=?	-	Frequency in Hz	OK/ AT_BUSY_ERROR ⁽¹⁾
@AT+RX1FQ=869535000	Frequency in Hz	-	OK/ AT_BUSY_ERROR ⁽¹⁾ AT_PARAM_ERROR ⁽²⁾
Example @AT+RX1FQ=?	-	869535000	OK
Example @AT+RX1FQ=	869535000	-	OK

1. AT_BUSY_ERROR 當加入或發送正在處理中返回
2. AT_PARAM_ERROR 表示設置錯誤或格式錯誤的值時會返回

7.3 @AT+TX1FQ: frequency of the transmitted channel 1

該命令允許用戶存取發射的通道 1 的頻率 (詳情參閱 [Table 48](#)).

Table 48. Frequency of the received window 2 command

Command	Input parameter	Return value	Return code
@AT+TX1FQ?	-	AT+TX1FQ: get or set the Tx1 frequency	OK
@AT+TX1FQ=?	-	Frequency in Hz	OK/ AT_BUSY_ERROR ⁽¹⁾
@AT+TX1FQ=869535000	Frequency in Hz	-	OK/ AT_PARAM_ERROR ⁽²⁾ AT_BUSY_ERROR ⁽¹⁾
Example @AT+TX1FQ=?	-	869535000	OK
Example @AT+TX1FQ=	869535000	-	OK

1. AT_BUSY_ERROR 當加入或發送正在處理中返回
2. AT_PARAM_ERROR 表示設置錯誤或格式錯誤的值時會返回

7.4 @AT+TX2FQ: frequency of the transmitted channel 2

該命令允許用戶存取發射的通道 2 的頻率 (詳情參閱 [Table 49](#)).

Table 49. Frequency of the received window 2 command

Command	Input parameter	Return value	Return code
@AT+TX2FQ?	-	AT+TX2FQ: get or set the Tx2 frequency	OK
@AT+TX2FQ=?	-	Frequency in Hz	OK/ AT_BUSY_ERROR ⁽¹⁾
@AT+TX2FQ=869535000	Frequency in Hz	-	OK/ AT_PARAM_ERROR ⁽²⁾ AT_BUSY_ERROR ⁽¹⁾
Example @AT+TX2FQ=?	-	869535000	OK
Example @AT+TX2FQ=	869535000	-	OK

1. AT_BUSY_ERROR 當加入或發送正在處理中返回
2. AT_PARAM_ERROR 表示設置錯誤或格式錯誤的值時會返回

7.5 @AT+TX3FQ: frequency of the transmitted channel 3

該命令允許用戶存取發射的通道 3 的頻率 (詳情參閱 [Table 50](#)).

Table 50. Frequency of the received window 2 command

Command	Input parameter	Return value	Return code
@AT+TX3FQ?	-	AT+TX3FQ: get or set the Tx3 frequency	OK
@AT+TX3FQ=?	-	Frequency in Hz	OK/ AT_BUSY_ERROR ⁽¹⁾
@AT+TX3FQ=869535000	Frequency in Hz	-	OK/ AT_PARAM_ERROR ⁽²⁾ AT_BUSY_ERROR ⁽¹⁾
Example @AT+TX3FQ=?	-	869535000	OK
Example @AT+TX3FQ=	869535000	-	OK

1. AT_BUSY_ERROR 當加入或發送正在處理中返回
2. AT_PARAM_ERROR 表示設置錯誤或格式錯誤的值時會返回

7.6 @AT+TX4FQ: frequency of the transmitted channel 4

該命令允許用戶存取發射的通道 4 的頻率 (詳情參閱 [Table 51](#)).

Table 51. Frequency of the received window 2 command

Command	Input parameter	Return value	Return code
@AT+TX4FQ?	-	AT+TX4FQ: get or set the Tx4 frequency	OK
@AT+TX4FQ=?	-	Frequency in Hz	OK/ AT_BUSY_ERROR ⁽¹⁾
@AT+TX4FQ=869535000	Frequency in Hz	-	OK/ AT_PARAM_ERROR ⁽²⁾ AT_BUSY_ERROR ⁽¹⁾
Example @AT+TX4FQ=?	-	869535000	OK
Example @AT+TX4FQ=	869535000	-	OK

1. AT_BUSY_ERROR 當加入或發送正在處理中返回
2. AT_PARAM_ERROR 表示設置錯誤或格式錯誤的值時會返回

7.7 @AT+TX5FQ: frequency of the transmitted channel 5

該命令允許用戶存取發射的通道 5 的頻率 (詳情參閱 [Table 52](#)).

Table 52. Frequency of the received window 2 command

Command	Input parameter	Return value	Return code
@AT+TX5FQ?	-	AT+TX5FQ: get or set the Tx5 frequency	OK
@AT+TX5FQ=?	-	Frequency in Hz	OK/ AT_BUSY_ERROR ⁽¹⁾
@AT+TX5FQ=869535000	Frequency in Hz	-	OK/ AT_PARAM_ERROR ⁽²⁾ AT_BUSY_ERROR ⁽¹⁾
Example @AT+TX5FQ=?	-	869535000	OK
Example @AT+TX5FQ=	869535000	-	OK

1. AT_BUSY_ERROR 當加入或發送正在處理中返回
2. AT_PARAM_ERROR 表示設置錯誤或格式錯誤的值時會返回

7.8 @AT+TX6FQ: frequency of the transmitted channel 6

該命令允許用戶存取發射的通道 6 的頻率 (詳情參閱 [Table 53](#)).

Table 53. Frequency of the received window 2 command

Command	Input parameter	Return value	Return code
@AT+TX6FQ?	-	AT+TX6FQ: get or set the Tx6 frequency	OK
@AT+TX6FQ=?	-	Frequency in Hz	OK/ AT_BUSY_ERROR ⁽¹⁾
@AT+TX6FQ=869535000	Frequency in Hz	-	OK/ AT_PARAM_ERROR ⁽²⁾ AT_BUSY_ERROR ⁽¹⁾
Example @AT+TX6FQ=?	-	869535000	OK
Example @AT+TX6FQ=	869535000	-	OK

1. AT_BUSY_ERROR 當加入或發送正在處理中返回
2. AT_PARAM_ERROR 表示設置錯誤或格式錯誤的值時會返回

7.9 @AT+TX7FQ: frequency of the transmitted channel 7

該命令允許用戶存取發射的通道 7 的頻率 (詳情參閱 [Table 54](#)).

Table 54. Frequency of the received window 2 command

Command	Input parameter	Return value	Return code
@AT+TX7FQ?	-	AT+TX7FQ: get or set the Tx7 frequency	OK
@AT+TX7FQ=?	-	Frequency in Hz	OK/ AT_BUSY_ERROR ⁽¹⁾
@AT+TX7FQ=869535000	Frequency in Hz	-	OK/ AT_PARAM_ERROR ⁽²⁾ AT_BUSY_ERROR ⁽¹⁾
Example @AT+TX7FQ=?	-	869535000	OK
Example @AT+TX7FQ=	869535000	-	OK

1. AT_BUSY_ERROR 當加入或發送正在處理中返回
2. AT_PARAM_ERROR 表示設置錯誤或格式錯誤的值時會返回

7.10 @AT+TX8FQ: frequency of the transmitted channel 8

該命令允許用戶存取發射的通道 8 的頻率 (詳情參閱 [Table 55](#)).

Table 55. Frequency of the received window 2 command

Command	Input parameter	Return value	Return code
@AT+TX8FQ?	-	AT+TX8FQ: get or set the Tx8 frequency	OK
@AT+TX8FQ=?	-	Frequency in Hz	OK/ AT_BUSY_ERROR ⁽¹⁾
@AT+TX8FQ=869535000	Frequency in Hz	-	OK/ AT_PARAM_ERROR ⁽²⁾ AT_BUSY_ERROR ⁽¹⁾
Example @AT+TX8FQ=?	-	869535000	OK
Example @AT+TX8FQ=	869535000	-	OK

1. AT_BUSY_ERROR 當加入或發送正在處理中返回
2. AT_PARAM_ERROR 表示設置錯誤或格式錯誤的值時會返回

7.11 @AT+SAVE: Save the customization configuration

該命令允許用戶存取客需參數 (詳情參閱 [Table 56](#)).

Table 56. Save customization configuration command

Command	Input parameter	Return value	Return code
@AT+SAVE	-		OK

7.12 @AT+TXO: transmit power without limitation by area, such as EU 868.

該命令允許用戶存取發射功率，且不受區域限制(如 EU 868) (詳情參閱 [Table 57](#)).

Table 57. Transmit power command

Command	Input parameter	Return value	Return code
@AT+TXO?	-	AT+TXO: get or set the transmit power (0-20)	OK
@AT+TXO=?	-	[0,1,2,3,4,5,6,7,8,9,10,11,12,13,14,15,16,17,18,19,20] ⁽²⁾	OK AT_PARAM_ERROR ⁽¹⁾
@AT+TXO=<input>	[0,1,2,3,4,5,6,7,8,9,10,11,12,13,14,15,16,17,18,19,20] ⁽²⁾	-	OK AT_PARAM_ERROR ⁽¹⁾
Example @AT+TXO=?	-	1	OK
Example @AT+TXO=	4	-	OK

1. AT_PARAM_ERROR 表示設置錯誤或格式錯誤的值時會返回

◆ CHANGE LIST

Rev	Date	Author	Change List
V1.0	2018.10.22	Kaysa Lee	Preliminary
V1.1	2019.04.18	Kelly Hsu	Add Additional Guidelines